

LINDY®

COMPUTER CONNECTION TECHNOLOGY

VGA to TV Converter

User Guide

English

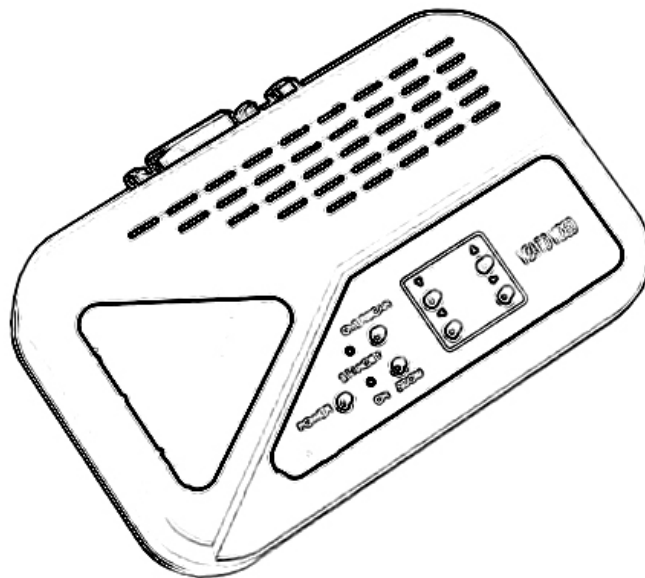

LINDY No. 32566

www.lindy.com



Introduction

Thank you for purchasing the LINDY VGA to TV Converter. This device allows you to view the output from a VGA Video port on any PAL compatible TV or projector for large screen viewing.

Features

- Compact desktop design
- Plug and Play no software driver required
- Compatible with PC and Mac computers
- Supports VGA modes, 1024 x 768, 800 x 600, 640 x 480
- Automatically adjusts scan rates from 50Hz up to 100Hz
- Simultaneous display on monitor and TV
- Composite, S-Video (S-VHS or Hi8) outputs supported (PAL)
- Dimensions: 145 x 95 x 35mm (WxDxH)

Operation Controls and Functions

1. **Standby indicator:** This indicator will light when the unit is in standby mode
2. **ON Indicator:** This indicator will light when in power ON mode
3. **Power Button:** Push this button to turn power ON or OFF
4. **Zoom Button:** Push this button to zoom the picture
5. **Overscan Button:** Push this button to overscan/underscan the picture
6. **Left Button:** Push this button to pan the picture left
7. **Right Button:** Push this button to pan the picture right
8. **Down Button:** Push this button to pan the picture down
9. **Up Button:** Push this button to pan the picture up

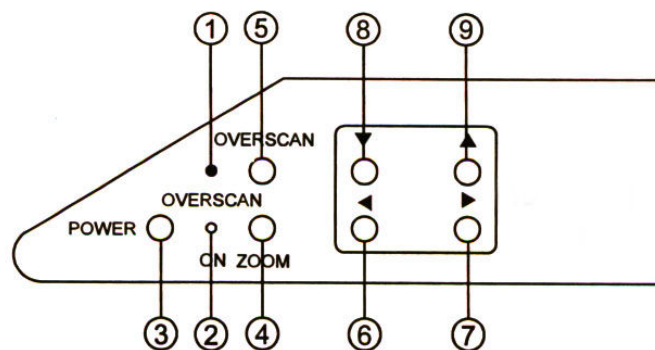

Installation

The LINDY VGA to TV Converter is a true Plug and Play device which does not require any software or drivers to operate. Simply attach the 15 way pass-through cable to the rear connector on the converter and then connect the 15 way HD male connector to your video card. Now simply connect the 15 way HD male cable from your monitor to the 15 way HD female connector on the pass-through cable. You will require either a composite video cable, or S-Video cable to connect from the converter to your TV or other compatible AV device.

Note: S-Video uses separate “Luminance” and “Chrominance “ signals and is the preferred connection method. If you’re TV does not support S-Video then use a composite cable.

Please refer to the diagram below for a typical application using the VGA to TV converter.

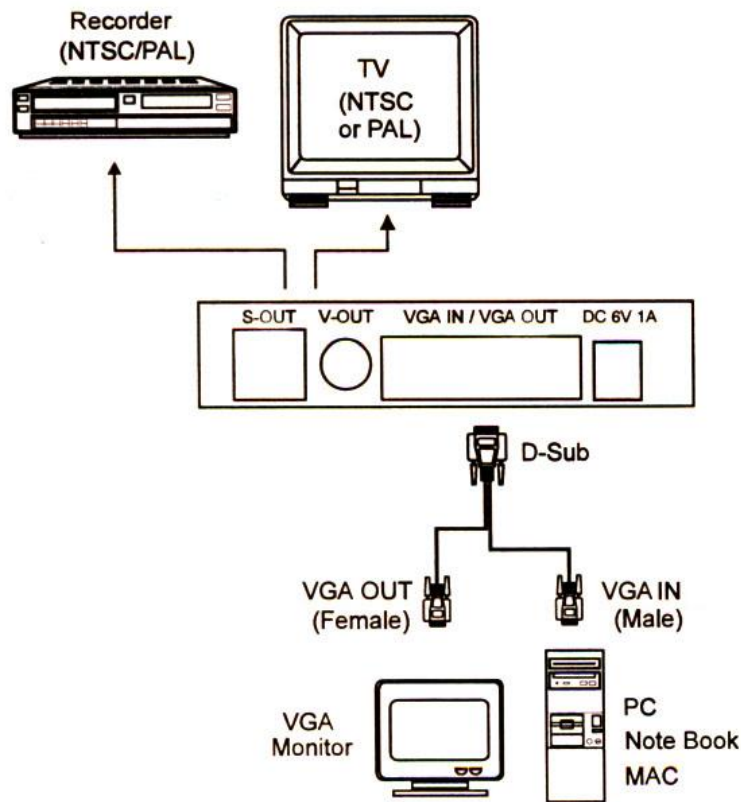

Power-Up Sequence

Ensure all equipment is turned off before connecting the VGA to TV converter. Once all cables are connected, apply power to the Television, then apply power to the converter and finally apply power to the source device.

Package Contents

- VGA to TV Converter
- 6V DC / 1 Amp power adapter (Centre negative)
- Pass-through VGA cable 1.2m
- This user guide

CE/FCC/WEEE Statement

CE Statement

This device complies with the European Regulations for Electromagnetic Compatibility (EMC) of the European Union and it is equipped with the CE mark. This unit has to be used with high quality shielded connection cables. Only if such high quality shielded cables are used can you be sure that the EMC compatibility is not adversely influenced.

FCC Statement

Shielded cables must be used with this equipment to maintain compliance with radio frequency energy emission regulations and ensure a suitably high level of immunity to electromagnetic disturbances.

FCC Warning

This equipment has been tested and found to comply with the limits for a Class B Digital device, pursuant to part 15 of the FCC Rules. These limits are designed to provide reasonable protection against harmful interference in a residential installation. This equipment generates, uses, and can radiate radio frequency energy and, if not installed and used in accordance with the instructions, may cause harmful interference to radio communications. However, there is no guarantee that interference will not occur in a particular installation. If this equipment does cause harmful interference to radio or television reception, which can be determined by turning the equipment off and on, the user is encouraged to try to correct the interference by one or more of the following measures:

- Reorient or relocate the receiving antenna
- Increase the separation between the equipment and receiver
- Connect the equipment into an outlet on a circuit different from that to which the receiver is connected
- Consult the dealer or an experienced technician for help

You are cautioned that changes or modifications not expressly approved by the party responsible for compliance could void your authority to operate the equipment.



**WEEE (Waste of Electrical and Electronic Equipment),
Recycling of Electronic Products**

United Kingdom

In 2006 the European Union introduced regulations (WEEE) for the collection and recycling of all waste electrical and electronic equipment. It is no longer allowable to simply throw away electrical and electronic equipment. Instead, these products must enter the recycling process.

Each individual EU member state has implemented the WEEE regulations into national law in slightly different ways. Please follow your national law when you want to dispose of any electrical or electronic products.

More details can be obtained from your national WEEE recycling agency.

Germany / Deutschland

Die Europäische Union hat mit der WEEE Richtlinie umfassende Regelungen für die Verschrottung und das Recycling von Elektro- und Elektronikprodukten geschaffen. Diese wurden von der Bundesregierung im Elektro- und Elektronikgerätegesetz – ElektroG in deutsches Recht umgesetzt.

Dieses Gesetz verbietet vom 24. März 2006 an das Entsorgen von entsprechenden, auch alten, Elektro- und Elektronikgeräten über die Hausmülltonne! Diese Geräte müssen den lokalen Sammelsystemen bzw. örtlichen Sammelstellen zugeführt werden! Dort werden sie kostenlos entgegen genommen. Die Kosten für den weiteren Recyclingprozess übernimmt die Gesamtheit der Gerätehersteller.

France

En 2006, l'union Européenne a introduit la nouvelle réglementation (WEEE) pour le recyclage de tout équipement électrique et électronique.

Chaque Etat membre de l' Union Européenne a mis en application la nouvelle réglementation WEEE de manières légèrement différentes. Veuillez suivre le décret d'application correspondant à l'élimination des déchets électriques ou électroniques de votre pays.

Italy

Nel 2006 l'unione europea ha introdotto regolamentazioni (WEEE) per la raccolta e il riciclo di apparecchi elettrici ed elettronici. Non è più consentito semplicemente gettare queste apparecchiature, devono essere riciclate.

Ogni stato membro dell' EU ha tramutato le direttive WEEE in leggi statali in varie misure. Fare riferimento alle leggi del proprio Stato quando si dispone di un apparecchio elettrico o elettronico.

Per ulteriori dettagli fare riferimento alla direttiva WEEE sul riciclaggio del proprio Stato.



No. 32566
www.lindy.com
